

- ▶ 10BASE-T1L (ADIN1100)
- ▶ USB-A connector
- ▶ Windows and Linux Raw-Ethernet device
- ▶ ADI ADIN1100 register access
- ▶ Flexible Software APIs

## Overview

The FC631 USB 10BASE-T1L Stick Raw represents a compact hardware interface connecting MS-Windows and Linux based PCs with industrial 10BASE-T1L Ethernet network devices and switches.

The FC631 USB 10BASE-T1L Stick Raw functions as full-featured Layer2 receiver and transmitter in an industrial Ethernet network. In comparison to the standard FC621 USB 10BASE-T1L Stick the FC631 USB 10BASE-T1L Stick Raw is not installed as network device on the Host PC, but comes with an API (Broadway2 C-API) to get full access to Layer2 raw data in an industrial 10BASE-T1L network.

The FC631 can be used for the analysis, simulation, test and validation of industrial Ethernet networks. Flexible software APIs feature full access to ADIN1100 PHY internal registers. This enables cable testing and network diagnosis.

## Features

### Hardware

- ▶ Analog Devices ADIN1100 10BASE-T1L PHY
- ▶ 10BASE-T1L physical interface with UTP connector
- ▶ NXP LPC4333 32-bit ARM Cortex-M4/M0 microcontroller
- ▶ High-Speed USB 2.0 device interface with Type-A connector
- ▶ Network Master/Slave configuration via hardware switch
- ▶ USB powered
- ▶ Compact and modular design

### Software

- ▶ MS-Windows and Linux compatible
- ▶ USB Bulk data In/Out to Ethernet Layer2
- ▶ Powerful and flexible API for ADIN1100 SMI access
- ▶ Common C-API and Python wrapper
- ▶ Python abstraction class for ADIN1100 MDIO register
- ▶ Python and C++ sample applications
- ▶ Firmware update via USB

## Applications

The USB interface of the FC631 USB 10BASE-T1L Stick Raw allows seamless connection to a broad variety of PCs, notebooks and embedded platforms. This enables the FC631 USB 10BASE-T1L Stick Raw for the following use cases:

- ▶ MS-Windows and Linux PC used as raw protocol analyzer for 10BASE-T1L networks
- ▶ Reception of raw Ethernet frames incl. 64-bit timestamp and sequence counter
- ▶ Decoding of ethernet raw frames with Python pypacker to ICMP, UDP/TCP-IP ..
- ▶ Transmission of Ethernet data supporting access to MAC, VLAN and raw data section
- ▶ Point-to-Point industrial Ethernet network connection using two USB 10BASE-T1L Sticks Raw
- ▶ Evaluation of Analog Devices ADIN1100 10BASE-T1L PHY chip with full access to MDIO registers
- ▶ 10BASE-T1L cable testing and network diagnosis
- ▶ Simulation of multiple nodes on industrial Ethernet switch designs
- ▶ Industrial Ethernet network simulation and demonstration

## Block Diagram

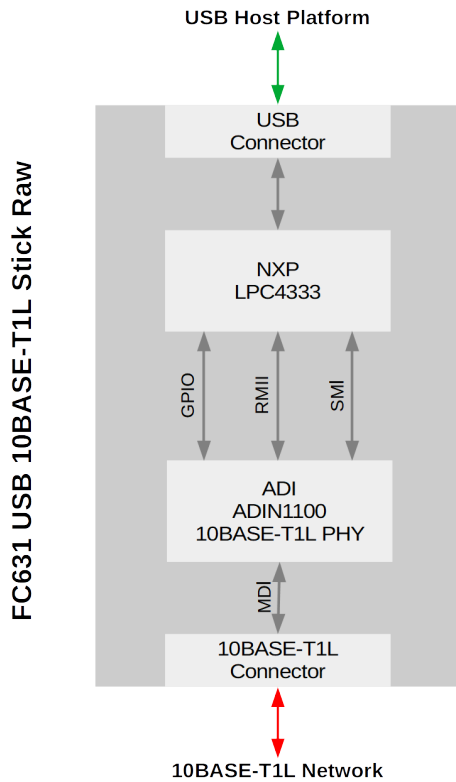

## Typical Application

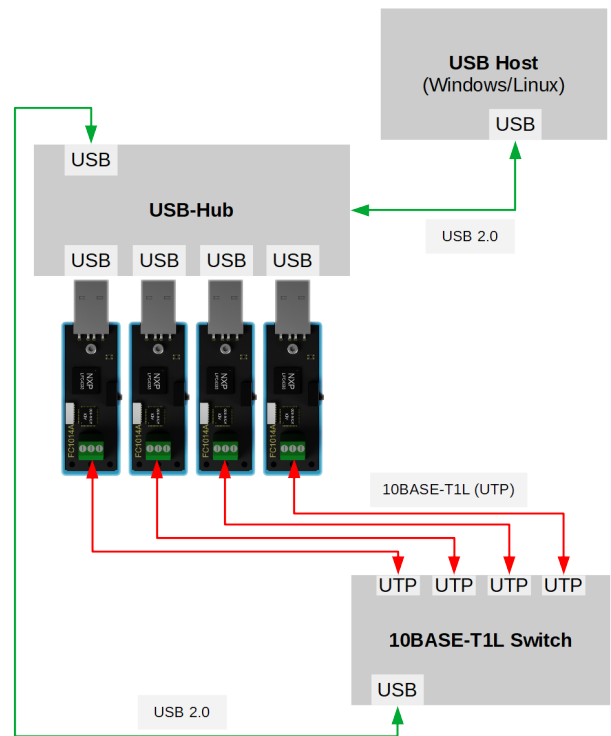

## Technical Data

Dimensions:	68 x 20 x 15 mm
Power Supply:	5 V (USB powered)
Temperature range:	0°C to +85°C
USB Connector:	USB 2.0 Type-A
10BASE-T1L Connector:	PTR screw terminal

## Ordering Information

Order Number:	FC631
Product Name:	USB 10BASE-T1L Stick Raw
Deliverables:	USB 10BASE-T1L Stick Raw incl. 2 m UTP Ethernet Cable and light blue sub-shell